

**SIMPLIFIED
STORMWATER MANAGEMENT
GUIDE**

FOR MINOR LAND DEVELOPMENT ACTIVITIES

March 2017

EAST MANCHESTER TOWNSHIP

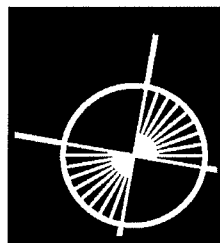

GLB&A

Gordon L. Brown & Assocs. Inc.
Consulting Engineers & Surveyors
2238 S. Queen St. York, Pa. 17402
(717) 741-4621

Site Sketch Plan Requirements:

The site sketch plan depicts the existing conditions of a property and the location of proposed impervious surfaces. Depicting the relationship between the proposed activities and distances to things like property lines, streams, and vegetated areas will help determine if the stormwater runoff created by the proposed project can be managed naturally within the property or if additional best management practices (BMPs) are needed to accommodate the stormwater runoff. The site sketch plan depicting key features should show the following:

- Property boundary.
- Location & dimension of all existing and proposed structures (house, shed, addition, etc.) and any proposed downspouts.
- Site conditions (grass areas, direction of slope and direction of stormwater flow on the property).
- Distance from proposed downspouts to property lines.
- All existing and proposed driveways, sidewalks and impervious areas (stone and gravel driveways are considered impervious).
- Natural features such as streams, wetlands, tree lines and other vegetation on the property.
- Distance from proposed structures or downspouts to any streams or wooded areas.
- Other information or site features applicable to stormwater runoff or project impact. (i.e. underground utilities)
- Wells and on-site septic systems.
- Utility Laterals

If BMPs are required, the following information must also be shown on the plan:

- Location and size of all proposed BMPs.
- Location of all new downspouts.
- If required, show site grading, indicating how increased runoff is being directed to the BMPs.

Stormwater Management- BMP Facilities & Maintenance Agreement:

For non DIAs, the applicant must provide stormwater management facilities or BMP's to address the increase in runoff from the site. The applicant shall be required to submit the following:

- Site Sketch Plan.
- Provide a BMP design acceptable to the Municipality. (Samples are included in the rear of the Stormwater Design Manual).
- Provide calculations indicating the proposed type and size of the BMP to meet minimum requirements. Sample calculation worksheet provided for the applicant.

Sample Stormwater Management Worksheet:

For non DIAs, the applicant must provide stormwater management facilities or BMP’s to address the increase in runoff from the site. The applicant shall be required to submit the following:

- Site Sketch Plan.
- Calculate the required volume of the stormwater infiltration structure created by the proposed impervious surfaces utilizing the following chart:

IMPERVIOUS AREA TO BED (SF)	DEPTH OF INFILTRATION STRUCTURE DESIGN TABLE														
	Area of Infiltration bed (SF)														
	10	20	30	40	50	60	70	80	90	100	110	120	130	140	150
50	2.1	1.0	0.7	0.5	0.4	0.3	0.3	0.3	0.2	0.2	0.2	0.2	0.2	0.1	0.1
100	4.2	2.1	1.4	1	0.8	0.7	0.6	0.5	0.5	0.4	0.4	0.3	0.3	0.3	0.3
200	8.3	4.2	2.8	2.1	1.7	1.4	1.2	1	0.9	0.8	0.8	0.7	0.6	0.6	0.6
300		6.3	4.2	3.1	2.5	2.1	1.8	1.6	1.4	1.3	1.1	1	1	0.9	0.8
400		8.3	5.6	4.2	3.3	2.8	2.4	2.1	1.9	1.7	1.5	1.4	1.3	1.2	1.1
500		10.4	6.9	5.2	4.2	3.5	3	2.6	2.3	2.1	1.9	1.7	1.6	1.5	1.4
600			8.3	6.3	5	4.2	3.6	3.1	2.8	2.5	2.3	2.1	1.9	1.8	1.7
700			9.7	7.3	5.8	4.9	4.2	3.6	3.2	2.9	2.7	2.4	2.2	2.1	1.9
800			11.1	8.3	6.7	5.6	4.8	4.2	3.7	3.3	3	2.8	2.6	2.4	2.2
900				9.4	7.5	6.3	5.4	4.7	4.2	3.8	3.4	3.1	2.9	2.7	2.5
1000				10.4	8.3	6.9	6	5.2	4.6	4.2	3.8	3.5	3.2	3	2.8

For bioretention or rain gardens, area of infiltration bed (shown in chart above) may be reduced by one third provided the bioretention/rain gardens are constructed per the applicable detail. Best management practices (BMPs) need to be used to manage the volume of stormwater created by the proposed impervious areas. The cubic feet of stormwater that needs to be managed may also be further reduced by planting new trees. If the criteria can be met, the amount of stormwater to be managed can be reduced per the following:

Deciduous Trees = 6 CF per tree

Evergreen Trees = 10 CF per tree

Criteria:

- Trees must be PA native species. (PA BMP Manual Appendix B)
- Trees shall be a minimum 2”-3” caliper tree and 6 feet tall (minimum)
- Trees shall be adequately protected during construction.
- No more than 50% of the required volume can be mitigated through the use of trees.
- Dead trees shall be replaced by the property owner within 12 months.
- Consider
- the specifications for each tree species when determining location and spacing.

Stormwater Management Exemption Criteria:

Impervious Area Exemption

Total Parcel Size	Exemption (square feet)
Less than 0.25 acre	1,000
0.25 to less than 0.5 acre	2,500
0.5 to 1 acre	5,000
More than 1 to 2 acres	10,000
More than 2 to 5 acres	15,000
More than 5 acres	20,000

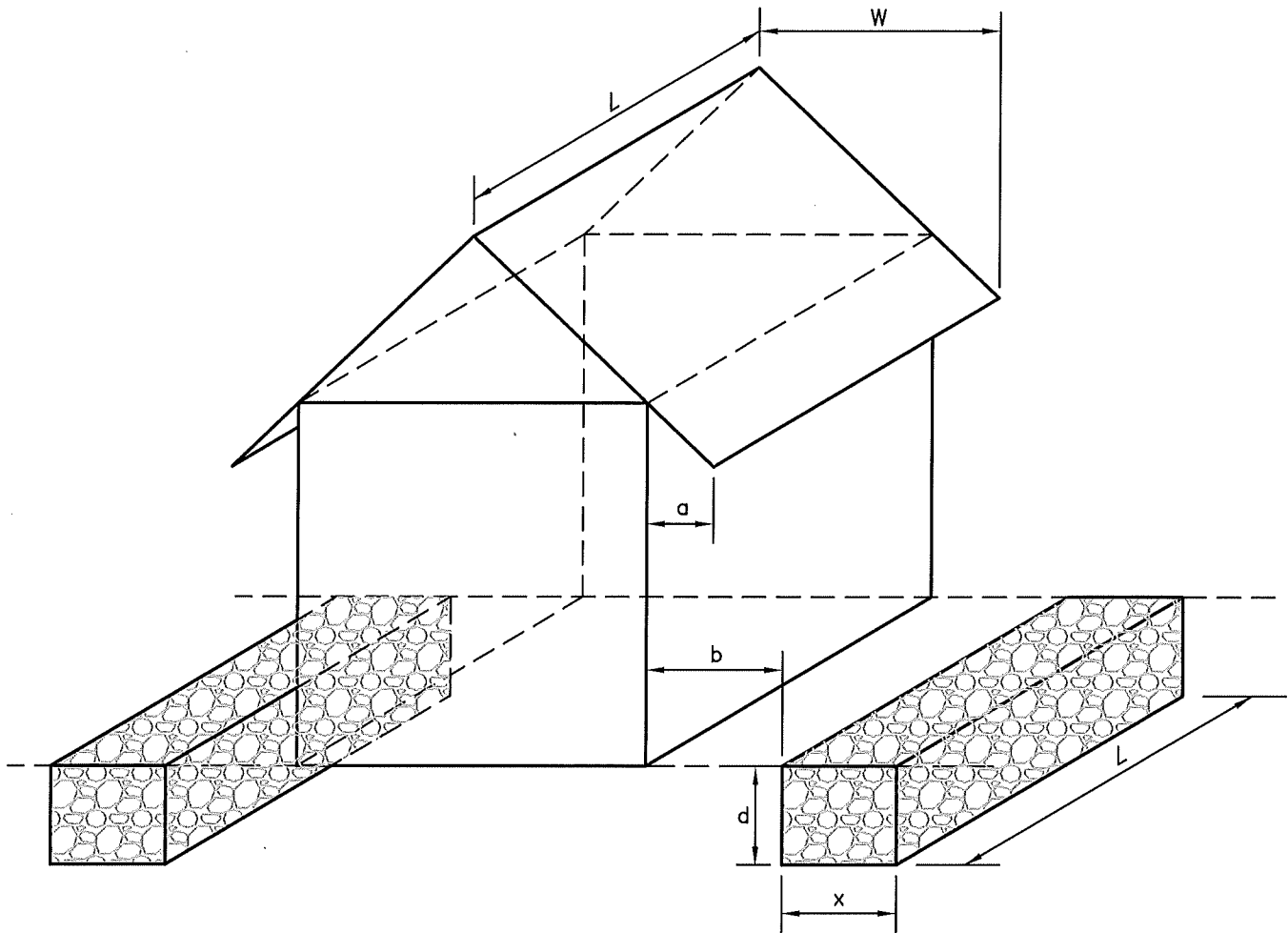

KEY

- L = LENGTH OF STRUCTURE ROOF = LENGTH OF SEEPAGE TRENCH (FT.)
- W = WIDTH OF ONE SIDE OF THE ROOF (FT)
- a = EAVE OVERHANG (FT)
- b = DISTANCE FROM STRUCTURE WALL TO SEEPAGE TRENCH (FT)
= a + 1 FT => PLACE EDGE OF TRENCH ONE FOOT PAST EAVES
- x = WIDTH OF SEEPAGE TRENCH (FT) => APPROXIMATELY 2 FT. TO 3 FT.
- d = DEPTH OF SEEPAGE TRENCH (FT)
- V = VOLUME

REQUIRED VOLUME OF TRENCH => $L*W*2/2 = V$
 PROVIDED VOLUME OF TRENCH => $L*d*x = V$

NOTES

- 1.) TRENCH MUST BE PROVIDED ON EACH SIDE OF STRUCTURE.
- 2.) TRENCH TO BE WRAPPED IN CLASS 1 WOVEN/NON-WOVEN GEOTEXTILE.
- 3.) TRENCH TO BE FILLED WITH CLEAN STONE (AASHTO #1 PREFERRED).
- 4.) TRENCH TO BE CONSTRUCTED AT 0% SLOPE ON UNDISTURBED SOIL.
- 5.) TRENCH TO BE CHECKED REGULARLY TO MAINTAIN PROPER OPERATION.

Date	Scale
03/27/17	N.T.S.
Drafter	Twp./County
S.J.S.	East Manchester Township York County, PA.
Sheet No.	Project No.
1 OF 1	Municipal

Gordon L. Brown & Associates, Inc.
 Civil Engineers & Surveyors

 2238 South Queen Street
 York, PA 17402-4631
GLB&A (717) 741-4621

STORMWATER MANAGEMENT
SAMPLE A
STRUCTURE WITHOUT GUTTERS

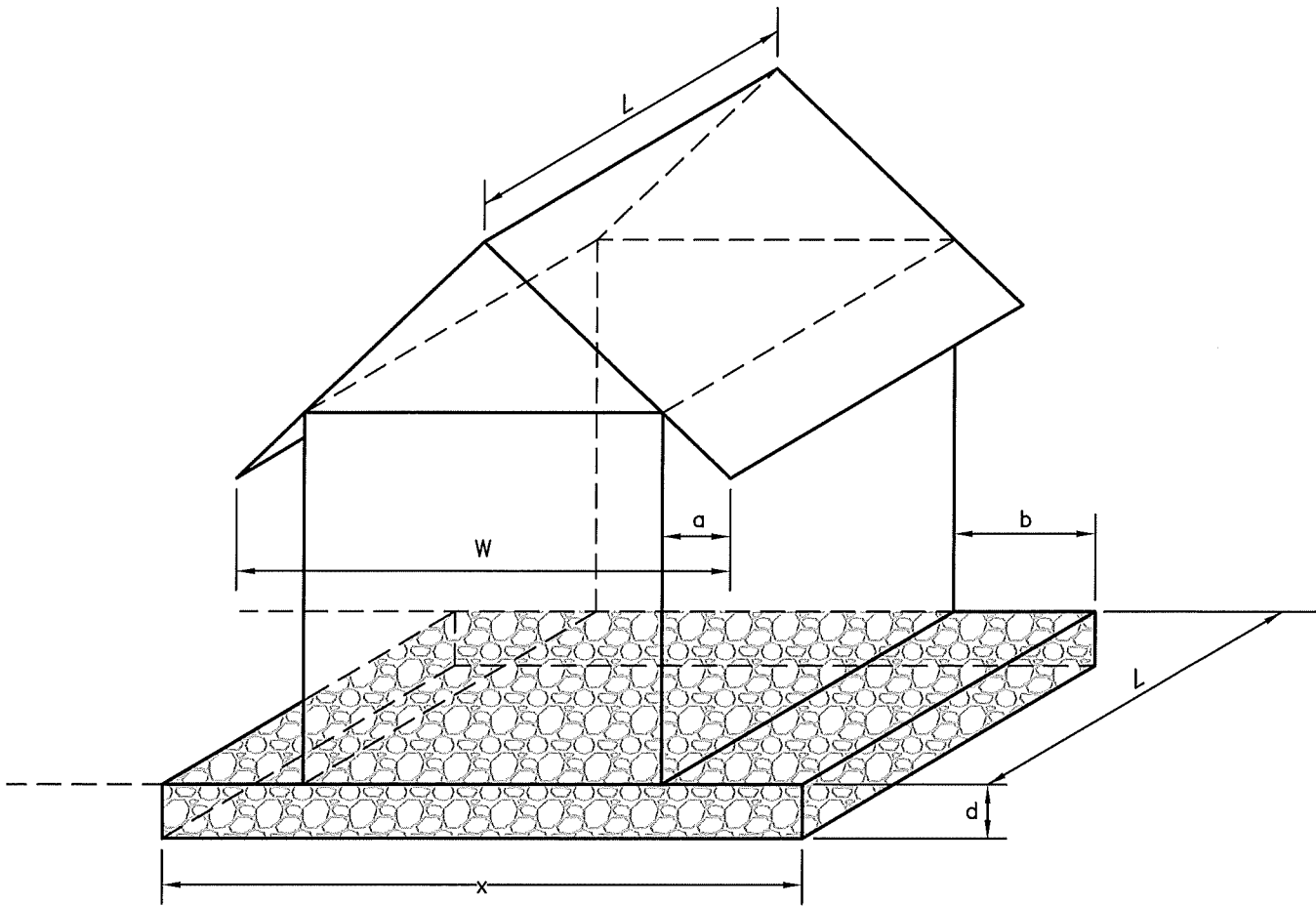

KEY

- L = LENGTH OF STRUCTURE ROOF = LENGTH OF SEEPAGE BED (FT.)
- W = WIDTH OF ENTIRE ROOF (FT)
- a = EAVE OVERHANG (FT)
- b = DISTANCE FROM STRUCTURE WALL TO SEEPAGE BED (FT)
= a + 1 FT => PLACE EDGE OF BED ONE FOOT PAST EAVES
- x = WIDTH OF SEEPAGE TRENCH (FT)
x = W + 2 FT
- d = DEPTH OF SEEPAGE TRENCH (FT)
d = 6" TO 8" (AVERAGE)

NOTES

- 1.) BED TO BE WRAPPED IN CLASS 1 NON-WOVEN GEOTEXTILE.
- 2.) BED TO BE FILLED WITH CLEAN STONE (AASHTO #1 PREFERRED).
- 3.) BED TO BE CONSTRUCTED AT 0% SLOPE ON UNDISTURBED SOIL.
- 4.) BED TO BE CHECKED REGULARLY TO MAINTAIN PROPER OPERATION.

Date	Scale
03/27/17	N.T.S.
Drafter	Twp./County
S.J.S.	East Manchester Township York County, PA.
Sheet No.	Project No.
1 OF 1	Municipal

Gordon L. Brown & Associates, Inc.
Civil Engineers & Surveyors



2238 South Queen Street
York, PA 17402-4631
GLB&A (717) 741-4621

STORMWATER MANAGEMENT
SAMPLE B
STRUCTURE WITHOUT GUTTERS

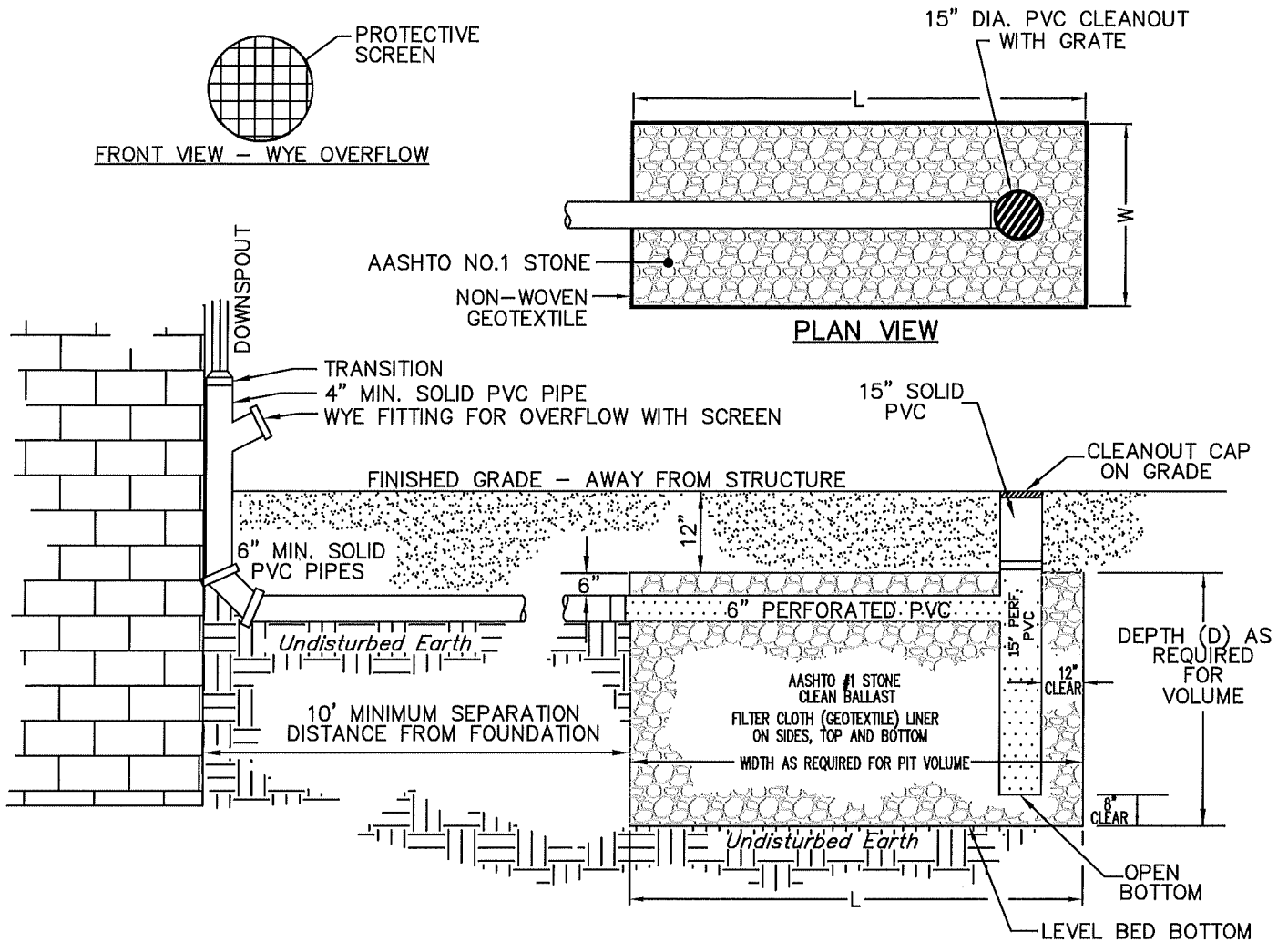

TYPICAL ROOF DRAIN & SEEPAGE PIT DETAIL

N.T.S.

REQUIRED VOLUME: $\text{AREA OF NEW IMPERVIOUS} / 2 = \text{REQUIRED VOLUME}$
 PROVIDED VOLUME: $L \times W \times D = \text{PROVIDED VOLUME}$

CONSTRUCTION NOTES:

1. HEAVY CONSTRUCTION VEHICLE TRAFFIC SHALL BE RESTRICTED FROM THE PROPOSED INFILTRATION AREAS TO PREVENT EXCESS COMPACTION.
2. FILTER FABRIC (CLASS 1 GEOTEXTILE) SHALL OVERLAP A MINIMUM OF 24 INCHES.
3. A MINIMUM OF TWELVE INCHES OF CLEARANCE IS TO BE MAINTAINED BETWEEN CLEANOUT & EDGE OF INFILTRATION STRUCTURE.

MAINTENANCE NOTES:

1. ALL CLEANOUT STRUCTURES DRAINING TO THE INFILTRATION BED SHALL BE CLEANED OUT ON A BI-ANNUAL BASIS.
2. THE PIT SHALL BE INSPECTED FOR CLOGGING, LITTER OR DEBRIS CAUSED BY EROSION FOUR (4) TIMES A YEAR AND FOLLOWING STORM EVENTS WITH OVER ONE (1) INCH OF PRECIPITATION.
3. REPLACE FILTER SCREEN THAT INTERCEPTS ROOF RUNOFF AS NECESSARY.

Date	Scale
03/27/17	N.T.S.
Drafter	Twp./County
S.J.S.	East Manchester Township York County, PA.
Sheet No.	Project No.
1 OF 1	Municipal

Gordon L. Brown & Associates, Inc.

Civil Engineers & Surveyors

2238 South Queen Street
York, PA 17402-4631

GLB&A (717) 741-4621

**ROOF DRAIN &
SEEPAGE PIT
DETAIL**

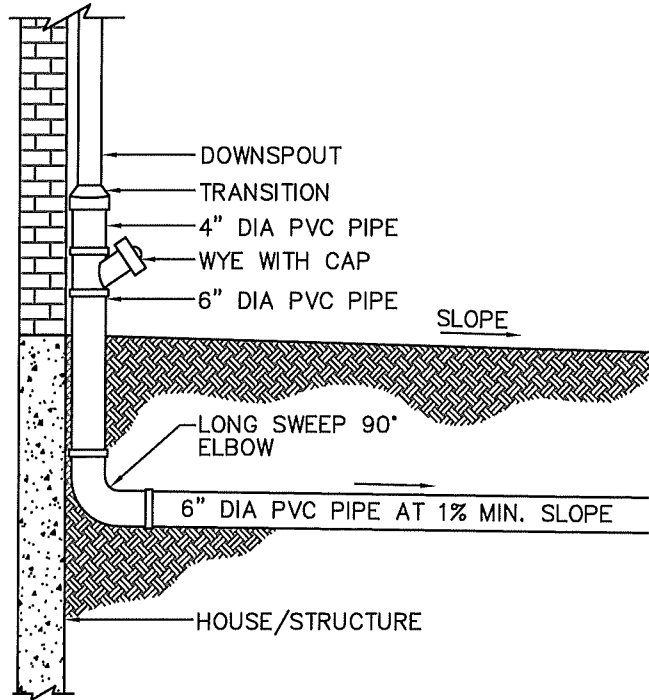

DOWNSPOUT CONNECTION DETAIL

N.T.S.

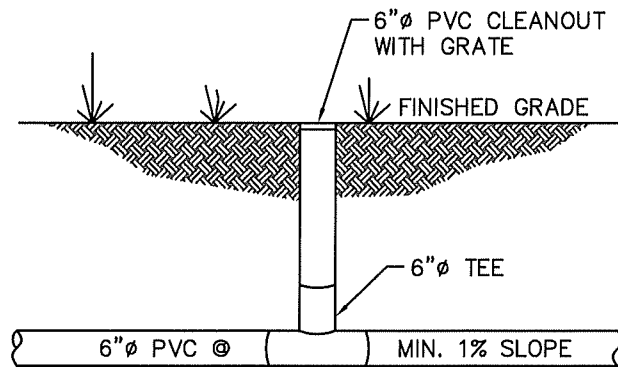

TYPICAL DOWNSPOUT CLEANOUT

N.T.S.

Date	Scale
03/27/17	N.T.S.
Drafter	Twp./County
S.J.S.	East Manchester Township York County, PA.
Sheet No.	Project No.
1 OF 1	Municipal

Gordon L. Brown & Associates, Inc.

Civil Engineers & Surveyors

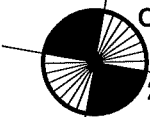

2238 South Queen Street

York, PA 17402-4631

GLB&A

(717) 741-4621

***DOWNSPOUT CONNECTION &
DOWNSPOUT CLEANOUT
DETAILS***

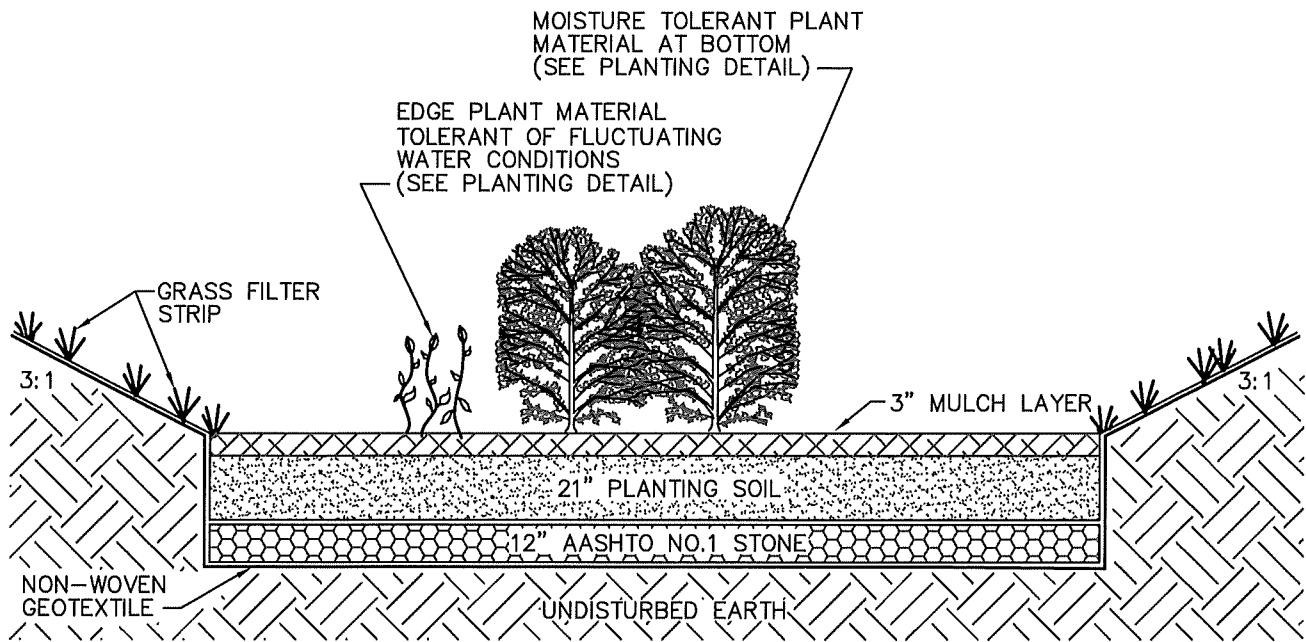

RAINGARDEN / BIORETENTION AREA DETAIL

N.T.S.

CONSTRUCTION NOTES:

1. HEAVY CONSTRUCTION VEHICULAR TRAFFIC SHALL BE RESTRICTED IN THE PROPOSED INFILTRATION AREAS TO PREVENT EXCESS COMPACTION.
2. FILTER FABRIC (NONWOVEN GEOTEXTILE) SHALL OVERLAP A MINIMUM OF 24 INCHES.
3. SOIL SHOULD BE A LOAM SOIL CAPABLE OF SUPPORTING A HEALTHY VEGETATED COVER. SOILS SHOULD BE AMENDED WITH A COMPOSTED ORGANIC MATERIAL (20-30% COMPOST), AND A 70-80% SOIL BASE (PREFERABLY TOPSOIL).
4. PLANTING SOIL SHOULD BE EXTENDED A MINIMUM OF 4" DEEPER THAN THE BOTTOM OF THE LARGEST ROOT BALL.
5. PLANTING SOIL SHALL BE INSTALLED IN 18" LAYERED LIFTS AND COMPACTED LIGHTLY. (TAMP WITH A BACKHOE BUCKET OR BY HAND).
6. MULCH TO BE SHREDDED HARDWOOD MULCH WITH A MINIMUM AGE OF SIX (6) MONTHS.
7. AGGREGATE TO BE PLACED IN SIX (6) INCH LIFTS AND LIGHTLY COMPACTED BETWEEN LIFTS.

MAINTENANCE NOTES:

1. ALL INLET STRUCTURES DRAINING TO THE INFILTRATION BED SHALL BE CLEANED OUT ON A BI-ANNUAL BASIS.
2. PRUNING AND WEEDING SHALL BE PERFORMED AS NECESSARY.
3. MULCH SHOULD BE REPLACED BI-ANNUALLY.
4. BASIN SHALL BE INSPECTED FOR CLOGGING, LITTER OR DEBRIS CAUSED BY EROSION FOUR (4) TIMES A YEAR AND FOLLOWING STORM EVENTS WITH OVER 1" OF PRECIPITAION.
5. BIORETENTION AREAS SHOULD NOT BE MOWED REGULARLY.
6. TREES AND SHRUBS SHALL BE INSPECTED TWICE A YEAR TO EVALUATE HEALTH.
7. DURING PERIODS OF EXTENDED DROUGHT, RAIN GARDENS MAY REQUIRE WATERING.
8. WEEDS SHOULD BE REMOVED FROM THE BASIN BY HAND.

Date	Scale
03/27/17	N.T.S.
Drafter	Twp./County
S.J.S.	East Manchester Township York County, PA.
Sheet No.	Project No.
1 OF 1	Municipal

Gordon L. Brown & Associates, Inc.

Civil Engineers & Surveyors

2238 South Queen Street
York, PA 17402-4631

GLB&A (717) 741-4621

BIORETENTION
AREA 1
DETAIL

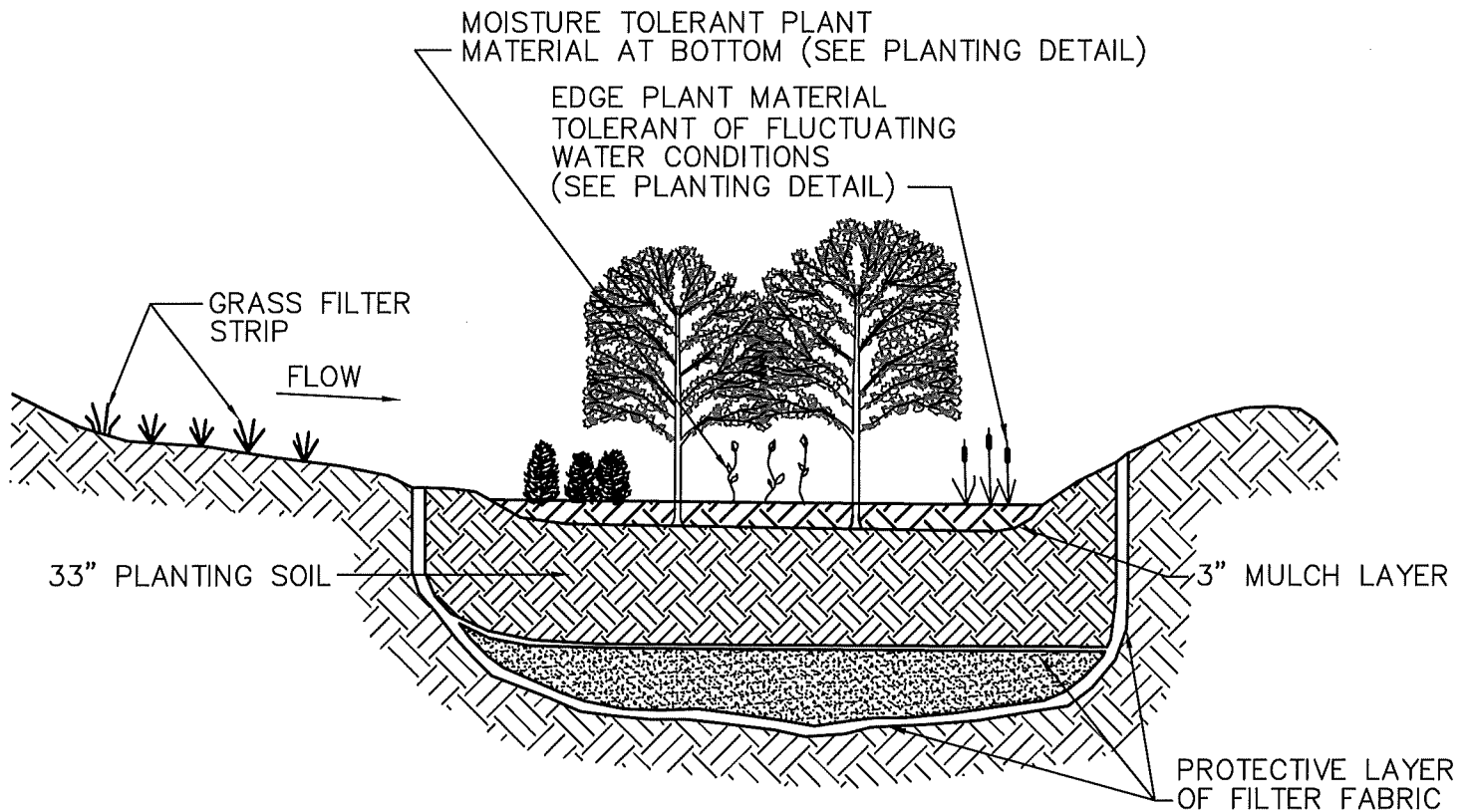

RAINGARDEN/ BIORETENTION AREA DETAIL

N.T.S.

CONSTRUCTION NOTES:

1. HEAVY CONSTRUCTION VEHICULAR TRAFFIC SHALL BE RESTRICTED TO THE PROPOSED INFILTRATION AREAS TO PREVENT EXCESS COMPACTION.
2. FILTER FABRIC SHALL OVERLAP A MINIMUM OF 24 INCHES.
3. SOIL SHOULD BE LOAM/SAND MIX OR SANDY LOAM CAPABLE OF SUPPORTING VEGETATIVE COVER; MODIFY SOIL WITH COMPOST IF NEEDED.

MAINTENANCE NOTES:

1. ALL INLET STRUCTURES DRAINING TO THE INFILTRATION BED SHALL BE CLEANED OUT ON A BI-ANNUAL BASIS.
2. PRUNING AND WEEDING SHALL BE PERFORMED AS NECESSARY.
3. MULCH SHOULD BE REPLACED ANNUALLY.
4. BASIN SHALL BE INSPECTED FOR CLOGGING, LITTER OR DEBRIS CAUSED BY EROSION FOUR TIMES A YEAR AND FOLLOWING STORM EVENTS WITH OVER 1" OF PRECIPITAION.

Date	Scale
03/27/17	N.T.S.
Drafter	Twp./County
S.J.S.	East Manchester Township York County, PA.
Sheet No.	Project No.
1 OF 1	Municipal

Gordon L. Brown & Associates, Inc.
Civil Engineers & Surveyors



2238 South Queen Street
York, PA 17402-4631
GLB&A (717) 741-4621

**BIORETENTION
AREA 2
DETAIL**

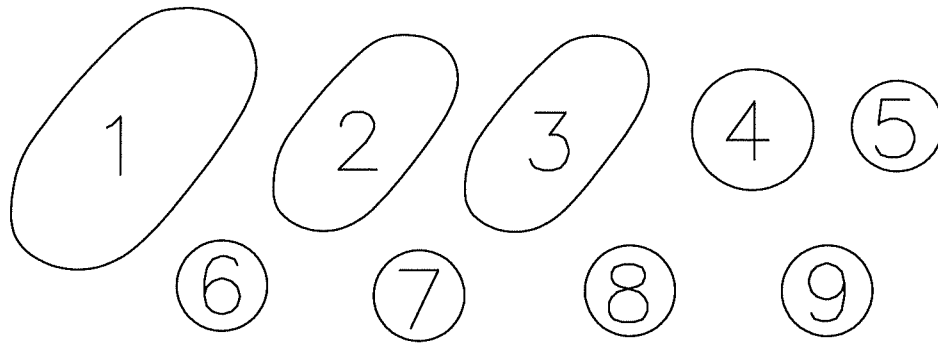

<u>KEY</u>	<u>COMMON NAME</u>	<u>LATIN NAME</u>	<u>CLASSIFICATION</u>
1.	RED OSIER DOGWOOD	CORNUS SERICEA	FACW+
2.	COMMON WINTERBERRY	ILEX VERTICILLATA	FACW+
3.	AMERICAN ELDER	SAMBUCUS CANADENSIS	FACW
4.	COMMON SNEEZEWEED	HELENIUM AUTUMNALE	FACW+
5.	CANADA GOLDENROD	SOLIDAGO CANADENSIS	FACU
6.	COMMON REED	PHRAGMITES AUSTRALIS	FACW
7.	SENSITIVE FERN	ONOCLEA SENSIBILIS	FACW
8.	MARSH BLUE VIOLET	VIOLA CUCULLATA	FACW+
9.	SWAMP SUNFLOWER	HELIANTHUS AUGUSTIFOLIUS	FACW

* AREAS BETWEEN ABOVE PLANTINGS TO BE SEEDED WITH THE FOLLOWING GRASSES:

RETENTION BASIN FLOOR SEEDING
LOW MAINTENANCE GRASS-LIKE
SPECIES ERNMX – 126:

- SPECIES: 20% REDTOP
 20% CREEPING BENTGRASS
 20% VIRGINIA WILD RYE
 20% FOX SEDGE
 20% ALKALI GRASS

APPLICATION RATE: 20 LBS/ACRE
 MAINTENANCE: 6" MINIMUM HEIGHT

SUGGESTED RAINGARDEN/BIORETENTION
AREA PLANTING DETAIL

N.T.S.

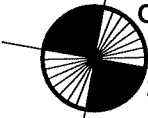
Date 03/27/17	Scale N.T.S.	Gordon L. Brown & Associates, Inc. Civil Engineers & Surveyors  2238 South Queen Street York, PA 17402-4631 GLB&A (717) 741-4621	BIORETENTION AREA PLANTING DETAIL
Drafter S.J.S.	Twp./County East Manchester Township York County, PA.		
Sheet No. 1 OF 1	Project No. Municipal		